



12,000lb 24V-DC Electric Winch

Owner's Manual



⚠️ WARNING: Read carefully and understand all ASSEMBLY AND OPERATION INSTRUCTIONS before operating. Failure to follow the safety rules and other basic safety precautions may result in serious personal injury.

Item #10801070/10801071

SAVE THESE INSTRUCTIONS

Thank you very much for choosing an X-POWER® product!

For future reference, please complete the owner's record below:

Serial Number/Lot Date Code: _____

Purchase Date: _____

Save the receipt, warranty, and this manual. It is important that you read the entire manual to become familiar with this product before you begin using it.

This electric winch is designed for certain applications only. Forcome Co., Ltd. is not responsible for issues arising from modification or improper use of this product such as an application for which it was not designed. We strongly recommend that this product not be modified and/or used for any application other than that for which it was designed.

For technical questions, please contact your local distributor

Thank you very much for choosing an X-POWER® product!

⚠️ WARNING

- Read and understand all instructions. Failure to follow all instructions may result in fire, serious injury and/or DEATH.
- The warnings and instructions in this manual cannot cover all possible conditions or situations that could occur. Exercise common sense and caution when using this electric winch. Always be aware of the environment and ensure the electric winch is used in a safe and responsible manner.
- Do not allow anyone to operate or assemble the electric winch until they have read this manual and have developed a thorough understanding of how it works.
- Do not modify this electric winch in any way. Unauthorized modification may impair the function and/or safety and could affect the life of the electric winch.
- Use the right tool for the job. DO NOT attempt to force small equipment to do the work of larger industrial equipment. There are certain applications for which this electric winch was designed. The tool will perform the job safer and better at the capacity for which it was intended. DO NOT use this equipment for a purpose for which it was not intended.
- Industrial or commercial applications must follow OSHA requirements.

Table of Contents



Intended Use.....	4
Technical Specifications	4
Important Safety Information	5
Specific Operation Warnings	6
Assembly Instructions.....	8
Before Each Use.....	10
Operating Instructions.....	11
After Each Use.....	14
Maintenance	14
Troubleshooting.....	15
Parts Diagram	16
Parts List	16
Replacement Parts	17
Warranty Information.....	18

Intended Use

The Rockland 12,000lb 24V DC Electric Vehicle Winch features a series-wound motor that stays cooler during long pulls. The three-stage planetary gear system provides fast line speed. The automatic load-holding brake ensures maximum safety. The free spooling provides a fast line-out. The winch has a Hawse fairlead and a rope.

Technical Specifications

Property	Specification
Rated Single Line Pull	12,000lb (5443kg)
Application	Vehicle Recovery / For Trucks and SUVs
Motor	24V DC 7.0 HP Series Wound
Power In & Power Out	Yes
Duty Cycle Rating	5% (45 seconds at Max Rated Load; 14 minutes, 15 seconds rest)
Remote Control	Wired, 12' (3.7m) Long
Gear Train	3-stage Planetary
Gear Ratio	232: 1
Free spool	Locking Ring Gear
Brake	Auto Load Holding
Drum (Dia. XL)	2.75" x 8.8" (70mm x 224mm)
Clevis Hook	3/8", Replaceable with Spring-Loaded Safety Latch
Fairlead	Hawse Fairlead
Rope Size/Type	0.375" x 82' (9.5mm x 25m) Aircraft Wire Rope: #10801070 synthetic Rope: #10801071
Battery	24V DC Minimum 650 CCA
Battery Cables	Min. 3.5 Gauge
Mounting Bolt Pattern	10"x 4.5" (254mm x 114.3mm)
Mounting Hardware	Winch: 4xG8, M10-1.50x30mm Fairlead: 2xG8, M12-1.75x25mm
Overload Protection	Built-in with remote
Sound Rating	85db
Overall Dimensions (LXDHX)	21.3" X 6.5" X 9.76" (540mm X 164mm X 248mm)
Weight	60lb (27.21kg)
IP Rating	IP68-Winch and Controls

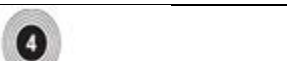
Layer	Rated Line pull	Rope Length/ Layer
 1	12000lb (5443kg)	19' (5.9m)
 2	9685lb (4393kg)	42' (12.8m)
 3	8119lb (3683kg)	68' (20.7m)
 4	6989lb (3170kg)	82' (25m)

First Layer of Rope Performance

	Line Pull lb (kg)	Line Speed fpm (m/min)	Amp Draw (DC12V)	Max. Pull Length ft (m)
	0 (0)	22 (6.7)	40	82 (25.0m)
	3000 (1361)	11 (3.4)	90	20 (6.1)
	6000 (2722)	8 (2.4)	120	8 (2.4)
	9000 (4082)	6 (1.8)	180	3 (1.0)
	12000 (5443)	5 (1.5)	210	1 (0.3)

Important Safety Information

⚠WARNING

WORK AREA SAFETY

- Inspect the work area before each use. Keep work area clean, dry, free of clutter and well-lit. Cluttered, wet or dark work areas can result in injury. Using the electric winch in confined work areas may put you dangerously close to other cutting tools and rotating parts.
- Keep children and bystanders away from the work area while operating the tool. Do not allow children to handle the electric winch.
- Always make sure you have control of vehicle and area around it. Make sure no personal or property damage can occur if vehicle rolls back during winching operation.

⚠WARNING

PERSONAL SAFETY

- Stay alert, watch what you are doing and use common sense when operating the electric winch. Do not use the electric winch while you are tired or under the influence of drugs, alcohol or medication. A moment of inattention while operating the tool may result in serious personal injury.
- Dress properly. Do not wear loose clothing, dangling objects or jewelry. Keep your hair, clothing, and gloves away from moving parts. Loose clothes, jewelry or long hair can be caught in moving parts. Air vents on the tool often cover moving parts and should be avoided.
- Wear the proper personal protective equipment when necessary. Use ANSI Z87.1 compliant safety goggles (not safety glasses) with side shields, or when needed, a face shield. Use a dust mask in dusty work conditions. Use non-skid safety shoes, hardhat, gloves, dust collection systems and hearing protection when appropriate. This applies to all persons in the work area.
- Do not overreach. Always keep proper footing and balance.

⚠CAUTION

WINCH USE AND CARE

- Inspect before every use. Do not use if parts are damaged, loose or missing. Examine the winch for structural cracks, bends, damage, frayed or kinked rope and any other conditions that may affect the safe operation of the winch. Do not use the winch even if minor damage appears. A kink permanently weakens the rope. Even after it is straightened out, kinked rope can fail suddenly and must not be used.
- Do not force the winch. Products are safer and do a better job when used in the manner for which they are designed. Plan your work and use the correct product for the job.
- Store the winch in a dry, secure place out of the reach of children when it is not in use. Inspect the tool for good working condition prior to storage and before re-use.
- Use only accessories that are recommended by the manufacturer for use with your product. Accessories that may be suitable for one product may create a risk of injury when used with another tool. Never use an accessory that has a lower operating speed or operating pressure than the tool itself.

Specific Operation Warnings

⚠WARNING

GENERAL SAFETY

- To prevent injury or property damage, read and understand all instructions before operating winch.
- Wear ANSI Z87.1 compliant safety goggles and heavy-duty leather work gloves during operation.
- Do not exceed the rated load capacity. Be aware of dynamic loading! Sudden load movement may briefly create excess load, causing product failure.

INSTALLATION SAFETY

- Choose a mounting location that can support the winch and rated load capacity.
- Do not weld mounting bolts.
- Use supplied power cords and rope listed in manual only. Do not use thinner/longer cables or link multiple cables together.
- Keep hands clear of winch rope, hook loop, hook and fairlead opening during installation, operation, and when spooling in or out.
- Wrap the rope under 1,000lb of tension before use. Otherwise, the rope may bind during operation.
- Do not route electrical cables near sharp edges or parts that will move or become hot.
- Work in a well-ventilated area. Explosive hydrogen gas can accumulate and explode when ignited by a spark or open flame.
- Only connect to a clean, corrosion-free battery.
- Remove all jewelry and metallic objects before working near battery.

WINCHING SAFETY

- Inspect winch rope, hook and slings before operating winch. Frayed, kinked or damaged winch rope must be replaced immediately. Damaged components must be replaced before operation.
- Do not maintain power to the winch if the motor stalls. Verify the load is within the rated capacity for the rope layer. Make sure the battery is fully charged. Use double-line rigging whenever possible.
- Do not engage or disengage clutch while under load.
- Always ensure hook latch is closed and not supporting load.
- Never apply load to hook tip or latch. Apply load only to the center of hook.
- Never use a hook that has been bent, warped or twisted.
- Keep clear of fairlead when operating. Do not try to guide rope.
- Do not place any fingers through the hook. Fingers may be caught and get pulled into the fairlead or drum. Use the included strap to hold the hook instead.
- Stay out of the direct line that the rope is pulling. If it slips or breaks, it will create a whiplash effect. Utilize a winch dampener to help absorb the force released if the rope breaks.
- Do not use for overhead hoisting. This winch is intended to be used for pulling only.
- Use a spotter to assist you with safe operation of the winch. Make sure the spotter is out of the way of the vehicle and the rope before activating the winch.
- Do not use the hand crank, if equipped, to assist the winch.
- Do not use vehicle to pull on the rope and assist the winch.
- Do not use to transport people or animals.
- Disconnect battery cables before working near the rope, drum, fairlead or load to prevent accidental starting.
- Keep rope straight to avoid kinking the rope.
- Keep children and bystanders away while operating.
- Hook onto the object using a pulling point, tow strap or chain. Do not wrap the rope around the object and hook onto the rope itself.
- Do not use a recovery strap while winching.
- Secure the load after moving. Do not lock the mechanism.
- Keep at least 8 full turns of rope on the drum.
- Keep clear of the rope, hook, and load while winching. Do not step over the rope or apply pressure to the rope under tension. The rope might break and cause personal injury.
- If the rope begins to get entangled, stop the winch immediately and release the rope using the switch.
- Only winch with the winching vehicle's transmission placed in neutral. Winching with a vehicle's transmission in gear or park may damage the transmission. A vehicle's transmission is not designed to handle this type of load.
- Do not operate the winch on extreme slopes. Do not exceed 45° from center line of vehicle for a roller fairlead. For a Hawse fairlead, the angle should be as close to vehicle center line as possible.
- People with pacemakers should consult their physicians before use. Electromagnetic fields near a heart pacemaker could cause pacemaker interference or failure.
- Remove all obstacles before operation.
- Always use supplied hook strap whenever spooling winch rope in or out, during

installation and during operation.

- Always take time to use appropriate rigging techniques for winch pull.

Assembly Instructions

⚠ WARNING

Read the entire Important Safety Information section at the beginning of this manual, including all text under subheadings, before setting up or using this electric winch.

Mounting the Winch:

1. The mounting plate must be rated to at least the winch's capacity. It must be flat and strong enough to remain flat at maximum winch capacity. The winch must sit flat on the winch mount with no gaps under drum supports.
2. Align the winch perpendicular to centerline of the vehicle at the desired location and mark the locations of the winch base holes. Compare the dimensions of the marked holes.
3. Before drilling, verify that the installation surface has no hidden components or structural pieces that will be damaged.

NOTE: This winch can generate extreme forces. Select a location that can withstand the rated capacity without damage or weakening. Steel reinforcement plates may be needed or a certified welder may need to weld on additional bracing, depending on the mounting location.

4. Drill holes for the hardware at the marked locations.
5. Install the winch using hardware described under the specifications table.

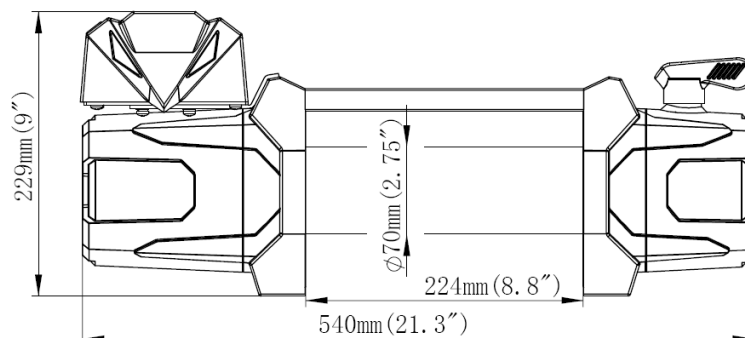
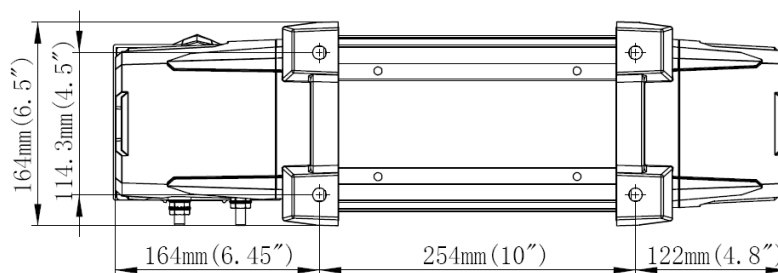

Wiring:

To prevent serious injury from explosion, due to sparking at the battery connection, disconnect the battery cables before making other wiring connections.

To prevent serious injury from leaking battery acid, do not use a dirty, corroded or leaking battery. Only use a 12V automotive (or equivalent) battery that is in good condition.

1. Plan a route for the wiring from the planned winch location to the battery. This route must be secure and out of the way of moving parts, road debris, or any possibility of being damaged by operation or maintenance of the vehicle. For example, you may wish to route the wires under the vehicle, attaching it to the frame using suitable fasteners. Do not attach the wires to the exhaust system, drive shaft, emergency brake cable, fuel line, or any other components which may damage the wiring through heat or motion, or create a fire hazard.
2. If you drill through the bumper or any part of the body to route the wires, be sure to install a rubber grommet in the hole to prevent fraying the wires.
3. Route the cables from the solenoid to the battery and from the solenoid to the winch, following the precautions discussed. See image below:

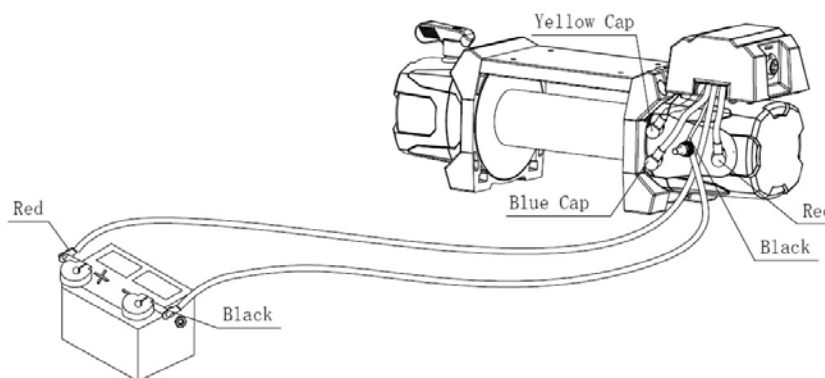

4. Attach the red, black and yellow cables to their corresponding terminals on the winch.
Note: Be sure to connect the small black wire from control pack to black (-) terminal on motor same terminal as negative (-) battery cable.
5. Attach the red battery cable to the positive terminal of the battery.
6. Attach the black battery cable directly to the negative terminal of the battery.
7. Lift the socket cover exposing the electrical switch connector. Insert the wired remote controller connector into the socket.
NOTE: The attachment of the motor cables determines the operation of the remote button. After the unit is mounted and powered, check the direction of the Power In and Power Out on the Remote button. If you wish to change the direction on the remote, disconnect the battery cables from the battery, switch the motor cable connections on the motor assembly, then reconnect the battery cables.
8. Disconnect the wired remote controller when not in use.

Preparing & Stretching Winch Rope:

WARNING: Always pre-stretch all new ropes before first use. Failing to pre-stretch rope will reduce maximum capacity of rope and may cause premature failure.

1. Position the vehicle on a flat surface approximately full rope length distance from anchor point, such as a large tree.
2. Connect rope to anchor point with minimum number of wraps on drum.
3. Recoil the rope back into the winch under at least 1000lb (454kg) of tension. Apply light pressure to vehicle brake pedal as needed to produce load.
4. Stop approximately every minute to check rope is winding uniformly on the drum. Make sure vehicle is in park with parking brake applied before exiting vehicle. Do not check, touch or attempt to reposition rope with load on winch rope.

Remote introduction:

1. "IN" Winch will power in with the red LED indicator light on
2. "OUT" Winch will power out with the blue LED indicator light on
3. Cored remote length: About 12ft
4. 5-way plug

Function:

1. Control the winch with "IN" to power in, the red LED will light up. "Out" to power out, the blue LED will light up.
2. Voltage detection: when the battery voltage is lower than 10.8V, the red and blue LED will flash. User should stop using the winch to avoid battery damage and turn on the engine while winching.
3. Stall load protection: When the winch pulling force is equal to the maximum rated capacity for more than 2 seconds, the winch protection will turn on. The red and blue LED will flash to indicate.
4. From "IN" to "OUT" or opposite direction, there will be a 50ms delay to ensure the life of the winch.
5. Ingress Protection Rating: IP68

NOTE: To maximize the life of the remote, store the remote in the vehicle and keep it away from oil or water.

Before Each Use

⚠ WARNING

- Inspect winch rope, hook and slings before operating winch. Frayed, kinked or damaged winch rope must be replaced immediately. Damaged components must be replaced before operation.
- Wrap the rope under 1000lbs of tension before use. Otherwise, the rope may bind during operation.
- Work in a well-ventilated area. Explosive hydrogen gas can accumulate and explode when ignited by a spark or open flame.
- Remove all jewelry and metallic objects before working near batteries.

Operating Instructions

⚠WARNING

- Read the entire Important Safety Information section at the beginning of this manual, including all text under subheadings, before setting up or using this electric winch.
- The instructions that follow are basic guidelines only and cannot cover all situations encountered during use. The operator and assistants must carefully plan usage to prevent accidents.

1. Examine the rope. Do not use the winch if the rope is frayed, kinked or damaged.
2. Fully charge the vehicle's battery.
3. Check the winch's electrical connections. All connections must be tight and clean.
4. Put the vehicle's transmission in Neutral.
5. If the vehicle connected to the winch must be stationary, engage the emergency brake and block the wheels using wheel chocks (sold separately).

WARNING: Never shift winch to Free Spool position with load on winch rope.

6. To pull out the rope, move the clutch control to the released position (shown below). Slide the loop of the hook strap over the hook, then pull on the hook strap to pull the winch rope from winch drum.



7. Hook onto the object using a pulling point, tow strap, tree strap, or chain.

⚠WARNING

Leave at least eight full turns of rope on the drum.

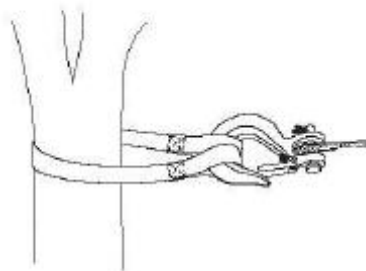

Do not wrap the rope around the object and hook onto the rope itself. This can damage the object being pulled and kink or fray the rope.

- The attachment point must be centered in loop of hook and the hook's safety clasp must be fully closed. (See image below.)

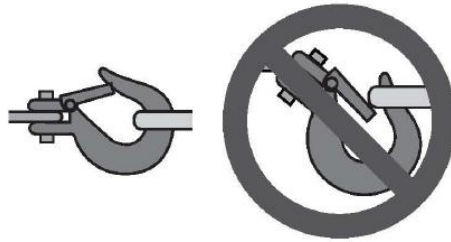

- Do not use a recovery strap while winching. They are designed to stretch and can suddenly whip back towards the operator during operation.
- Place a heavy rag or carpet (sold separately) over the rope span, 6 feet from the hook, to help absorb the force released if the rope breaks.

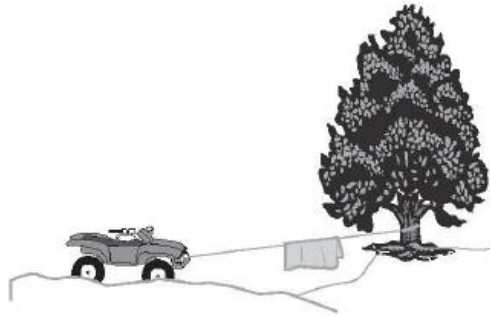

- Re-engage the clutch by moving the clutch handle to the engaged position (see image below)

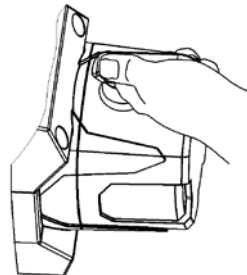

⚠WARNING

Do not allow anyone to stand near the rope or in line with the rope behind the winch while it is under power. If the rope should slip or break, it can suddenly whip back towards the winch, causing a hazard for anyone in the area. Stand far to the side while winching.

- Attach the wired remote controller to the socket on the solenoid assembly. (see image below).

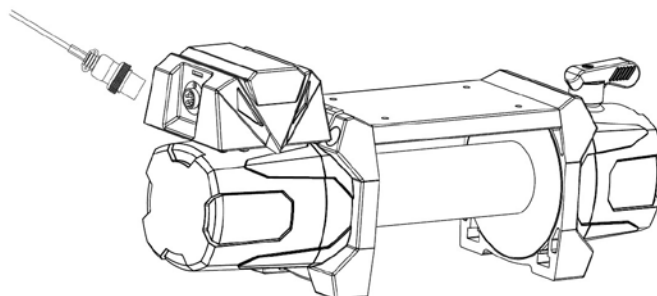

13. Operate the wired remote controller briefly to ensure the controls work properly. If operation is reversed, the power cables may be connected backwards. Correct any such issue before use.

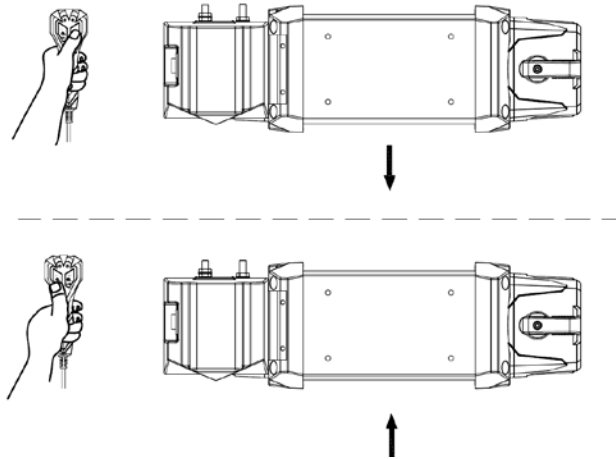

⚠ WARNING

Only operate the winch while the winch, line and load are in view. Make sure that there are no bystanders nearby.

14. When it is safe to do so, use the power switch on the wired remote controller to retract the rope, and winch the item as desired. To prevent damage, do not power the hook all the way into the fairlead to prevent damage.
15. Do not operate the winch at extreme angles. Do not exceed the angles shown below for a roller fairlead. For a Hawse fairlead, the angle should be as close to straight as possible.

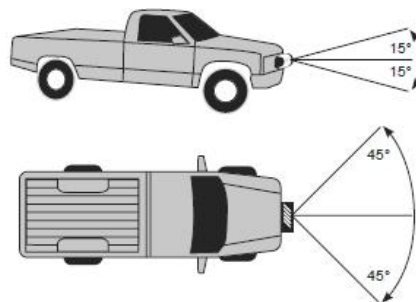

16. If the object to be pulled must be pulled at an angle in relation to the winch, use a pulley (sold separately) and an anchor point directly in front of the winch, as shown in the following picture.

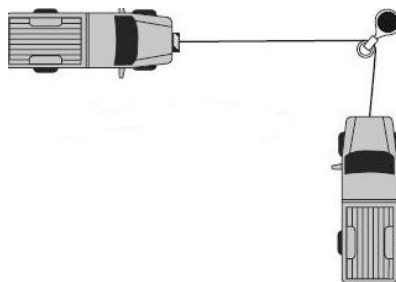

⚠ WARNING

Stop the winch and release tension on the rope before moving the rag or carpet placed on it.

17. Discontinue use of the winch if the battery becomes weak or run down.
18. You may wish to keep the engine running while using this winch, to continually recharge the battery. However, exercise extreme caution when working around a running vehicle and ONLY operate a vehicle in an outdoor area.
19. When finished pulling the load, reverse the direction of the winch just enough to release tension on the rope so that you can unfasten the hook from the load and reel in the rope.

Duty Cycle (Duration of Use):

Avoid damage to the winch by not winching for more than the prescribed duty cycle time. The Duty Cycle defines the amount of time, within a 15-minute period, during which a winch can operate at its maximum capacity without overheating.

For example, this winch with a 5% duty cycle at 65% maximum load must be allowed to rest for at least 14 minutes, 15 seconds after every 45 seconds of continuous operation.

Failure to carefully observe duty cycle limitations can easily over-stress a winch, causing premature winch failure.

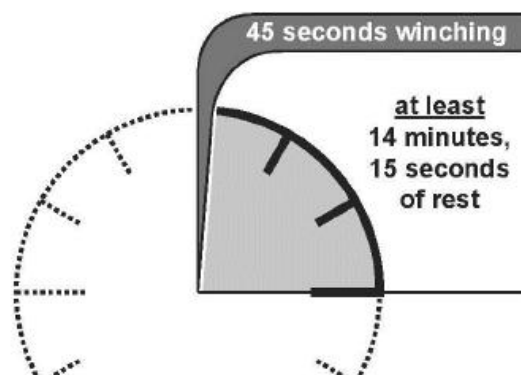

Do not attempt to pull full rated load for more than 20 seconds. Release Power-In switch immediately when winch drum/rope stops. Allow winch to cool and change rigging as needed before continuing pull.

After Each Use

- Inspect rope for damage. Replace immediately if damaged.
- Wipe external surfaces of the winch with a clean cloth.

Maintenance

⚠WARNING

- To prevent serious injury from accidental operation, disconnect the battery cables before performing any inspection, maintenance, or cleaning procedures.
- To prevent serious injury from winch failure, do not use damaged equipment. If an abnormal noise or vibration occurs, have the problem corrected before further use.
- The winch’s internal mechanism is permanently lubricated. Do not open the housing. However, if the winch is submerged, it should be opened, dried, and re-lubricated by a qualified technician as soon as possible to prevent corrosion.

Troubleshooting

⚠WARNING

- Follow all safety precautions whenever diagnosing or servicing the tool.
- Disconnect power supply before service.

Use the table below to troubleshoot problems before contacting service personnel. If the problem continues after troubleshooting, call **1-800-545-9633** for assistance.

Failure	Possible Cause	Corrective Action
Motor overheats	<ol style="list-style-type: none"> 1. Incorrect power cords 2. Winch is being over-worked 	<ol style="list-style-type: none"> 1. Use only supplied power cords 2. Allow winch to cool down periodically
Motor does not turn on	<ol style="list-style-type: none"> 1. Switch assembly not connected properly. 2. Loose battery cable connections 3. Vehicle battery needs charging 4. Solenoid malfunctioning 5. Defective switch assembly 6. Defective motor 7. Water has entered motor 8. Internal damage or wear 	<ol style="list-style-type: none"> 1. Insert switch assembly all the way into connector. 2. Tighten nuts on all cable connections 3. Fully charge battery 4. Tap solenoid to loosen contacts. Apply 12 volts to coil terminals directly. A clicking indicates proper activation 5. Replace switch assembly 6. Check for voltage at armature port with switch pressed. If voltage is present, replace motor 7. Allow to drain and dry. Run in short bursts without load until completely dry 8. Have technician service winch
Motor runs but rope drum does not turn	The clutch is not engaged	Move the Clutch Handle to the engaged position. If problem persists, contact a qualified technician to check and repair unit.
Motor runs slowly or without normal power	<ol style="list-style-type: none"> 1. Insufficient current or voltage 2. Loose or corroded battery cable connections 3. Incorrect power cords 	<ol style="list-style-type: none"> 1. Battery weak, recharge Run winch with vehicle motor running 2. Clean, tighten, or replace 3. Use only supplied power cords
Motor runs in one direction only	<ol style="list-style-type: none"> 1. Defective or stalled solenoid 2. Defective switch assembly. 	<ol style="list-style-type: none"> 1. Tap solenoid to loosen contacts. Or repair / replace the solenoid 2. Replace switch assembly

Parts Diagram

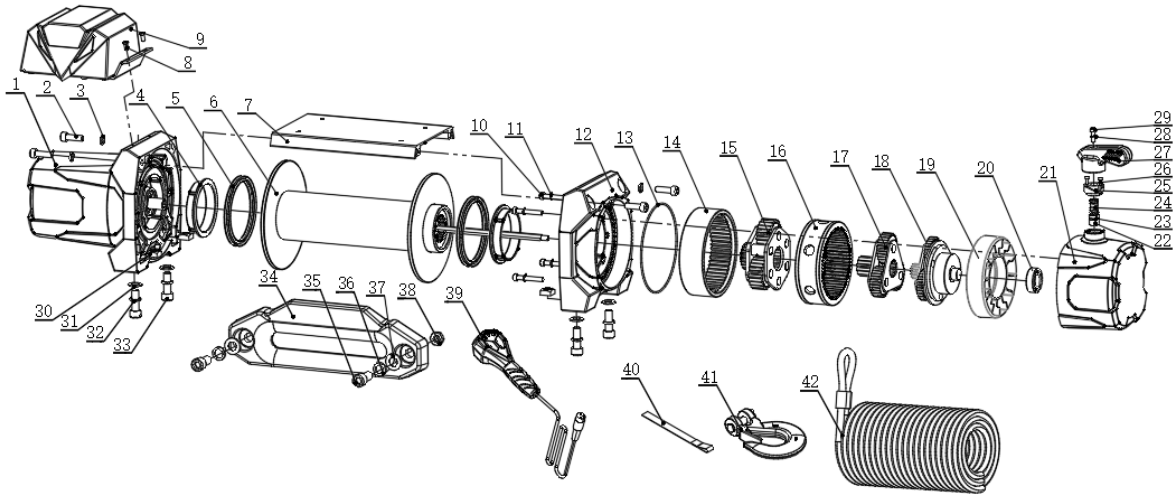

Parts List

Item Number	Description	Quantity	Set Number
1	Motor Assembly	1	A
2	Tie Bar Screw M8x30	4	
3	Tie Bar Washer Ø8	4	
4	Nylon Bearing	2	
5	Seal Kit	2	
6	Drum Assembly	1	B
7	Support Plate	1	C
8	Hex Socket Head Countersunk Screw M5 x10	4	D
9	Non-Integrated Control Pack	1	
10	Tie Bar Screw M6x50	4	E
11	Tie Bar Washer Ø6	4	
12	Gear Box Base	1	
13	O Ring 125 x2	1	
14	3 Stage Ring Gear	1	
15	Gear Carrier Assembly (Output)	1	
16	Clutch Gear	1	
17	Gear Carrier Assembly (Intermediate)	1	
18	Gear Carrier Assembly (Input)	1	
19	Baffle Plate	1	
20	Bearing	1	
21	Deceleration Box	1	F
22	Clutch Pin	1	
23	O Ring 10.6 x1.8	1	
24	Clutch Spring	1	
25	Clutch Cap	1	
26	Tie Bar Screw M3x16	1	
27	Clutch Handle	1	
28	Tie Bar Screw M5x14	1	
29	Tie Bar Washer Ø5	1	
30	Square Nut M10	4	G
31	Flat Washer Ø 10	4	
32	Spring Washer Ø 10	4	
33	Tie Bar Screw M10x30	4	
34	Hawse Fairlead	1	H
35	Tie Bar Screw M12x25	2	
36	Spring Washer Ø 12	2	

Item Number	Description	Quantity	Set Number
37	Flat Washer Ø 12	2	
38	Nut M12	2	
39	Pendant Controller	1	I
40	Red Strap	1	J
41	Clevis Hook	1	
42	Aircraft Wire Rope: #10801070 synthetic Rope: #10801071	1	

Replacement Parts

- For replacement parts and technical questions, please contact your local distributor.
- Not all product components are available for replacement. The illustrations provided are a convenient reference to the location and position of parts in the assembly sequence.
- When ordering parts, the following information will be required: item description, item model number, item serial number/item lot date code, and the replacement part number.
- The distributor reserves the rights to make design changes and improvements to product lines and manuals without notice.

Limited Warranty

Forcome Co., Ltd ("We" or "Us") warrants to the original purchaser only ("You" or "Your") that the X-POWER® product purchased will be free from material defects in both materials and workmanship, normal wear and tear excepted, for a period of one year from date of purchase. The foregoing warranty is valid only if the installation and use of the product is strictly in accordance with product instructions. There are no other warranties, express or implied, including the warranty of merchantability or fitness for a particular purpose. If the product does not comply with this limited warranty, Your sole and exclusive remedy is that We will, at our sole option and within a commercially reasonable time, either replace the product or product component without charge to You or refund the purchase price (less shipping). This limited warranty is not transferable.

Limitations on the Warranty

This limited warranty does not cover: (a) normal wear and tear; (b) damage through abuse, neglect, misuse, or as a result of any accident or in any other manner; (c) damage from misapplication, overloading, or improper installation; (d) improper maintenance and repair; and (e) product alteration in any manner by anyone other than Us, with the sole exception of alterations made pursuant to product instructions and in a workmanlike manner.

Obligations of Purchaser

You must retain Your product purchase receipt to verify date of purchase and that You are the original purchaser. To make a warranty claim, contact your local distributor, identify the product by make and model number, and follow the claim instructions that will be provided. The product and the purchase receipt must be provided to Us in order to process Your warranty claim. Any returned product that is replaced or refunded by Us becomes our property. You will be responsible for return shipping costs or costs related to Your return visit to a retail store.

Remedy Limits

Product replacement or a refund of the purchase price is Your sole remedy under this limited warranty or any other warranty related to the product. We shall not be liable for: service or labor charges or damage to Your property incurred in removing or replacing the product; any damages, including, without limitation, damages to tangible personal property or personal injury, related to Your improper use, installation, or maintenance of the product or product component; or any indirect, incidental or consequential damages of any kind for any reason.

Assumption of Risk

You acknowledge and agree that any use of the product for any purpose other than the specified use(s) stated in the product instructions is at Your own risk.



Distributed by:
Forcome (Shanghai) Co., Ltd
Building 109, No. 255 South Sizhuan Road
Shanghai 201612
China
Made in China